

Hopper vibrating bottom

DESCRIPTION

The hopper vibrating bottom is made from a basis of dented bottom equipped of an outlet cone. An intern conic jet deflector is hold in the internal dented bottom by beams in profiled welded on edge in order to avoid the product retention.

A vibrating motor – two in certain cases – is fixed outside the dented bottom. The vibrations amplitude is adjustable by positioning of the unbalances in each extremity of the motor shaft.

This set is hung on the silo basis thanks to suspensions provided of elastic articulation in each extremity in order to avoid vibrations transmission to the silo walls. The number of hangers depends on the type of hopper vibrating bottom. These hangers are connected to the silo thanks to a support flange soldered or bolted on the silo. This flange belongs to our supply.

An EPDM dustproof sleeve with an H shape assures a perfect sealing between the flange support and the hopper vibrating bottom. For the security, two clamp collars guaranty the maintenance.

The anticharge internal cone diameter is smaller than the silo opening. The annular space which is resulted is calculated to assure the desired flow.

The dimensions of the hopper bottom are determined by several parameters: the silo dimensions, the product characteristics physically and the desired flow. It can vary between 1/3 of the silo diameter for products with free flowing and 1/1 for fibrous or fluffy products. Some others factors can be taken in consideration in order to answer to you need.

The hopper bottom outlet is connected by flexible liaison to the followed equipment to avoid vibrations transmissions.

WORKING

Most of flowing problems with difficult products come from the products slope in the basis of the silos.

We have remedied by cancelling the section where the packing down is and by substituting by a hopper bottom. The external vibrating motor force in the horizontal plan breaks the vertical bypass operation created by the product between the anticharge cone and the dented bottom in order to trigger the flowing towards the outlet cone. The horizontal vibrations act by the intermediary of an anticharge cone which conveys them in the product to break any vaulting susceptible to be formed.

The hopper bottom establishes mass flowing conditions in the whole silo. This situation balances the setting of movement of the product which drains with the same speed from the peripheral annular zone to the silo centre, by reducing the segregation effect occurred during the filling in. The formation of the chimneys in the silo can be occurred because the product situated in the centre rests on vibrating anticharge cone.

The aired products with low density, susceptible to cause slides, can be handled effectively. Indeed, the vibrations of the conic deflector liberate the air included in the product and increase its density in a sufficient proportion to handle in a normal way.

The only maintenance consists in greasing periodically the external vibration motor.

INSTALLATION

The hopper vibrating bottom is supplied wholly assembled, ready to be set up under new or already installed silos.

The wiring flange supplied with each hopper bottom is soldered or bolted in the basis of the silo. The hopper bottom is then hung on this flange by suspension hangers and their shock absorbers. A flexible sleeve installed between the flange and the hopper bottom assures a perfect sealing.



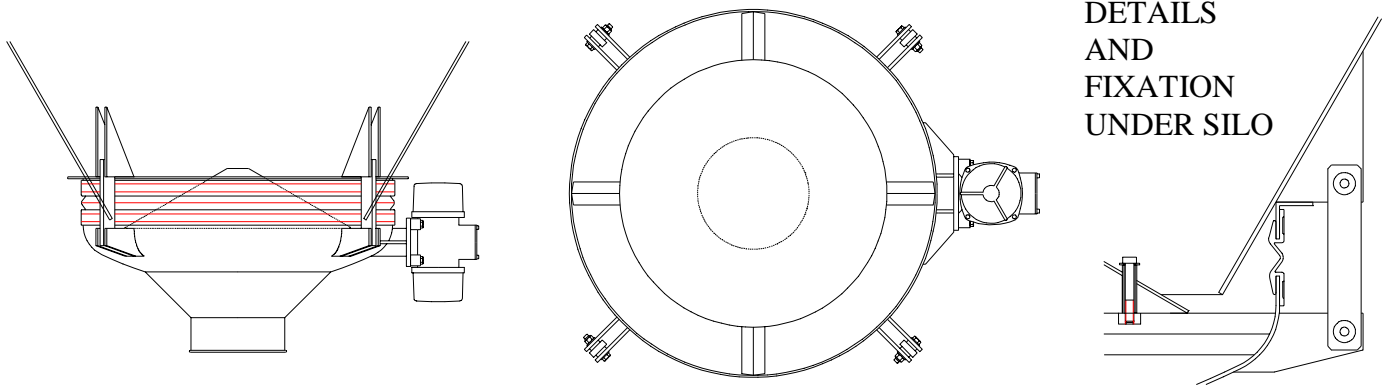

Diam. Standard	600	650	800	900	1000	1200	1250	1500	1600	1800	2000	2500	3000	3600
----------------	-----	-----	-----	-----	------	------	------	------	------	------	------	------	------	------

Sinex conceives and makes specific and adapted materials according to your need.

APPLICATIONS

The SINEX hopper vibrating bottom is the proof on the possibility to obtain a continuous and regular flowing with difficult products stockpiled in silos by the medium of appropriated vibrations.

It is established that, with the effect of vibration, the friction coefficient of the product decreases while the apparent density of the product increases.

By its neatly studied conception, the hopper bottom eliminates the possibilities of vaulting, of chimneys, of degradation and segregation of products in the silo. By its appropriated dimensions, it will allow a “mass” flowing following the principle of “first getting in – first getting out”.

The hopper bottom adapts itself perfectly with cylindrical shape hoppers. It could also be set up, with no difficulty, under rectangular or squared silos.

Comparing with a silo assuring an orbital flowing, the low jamming of the vibrating bottom allows an important reduction of the silo whole length, and the cost.

SINEX INDUSTRIE experience in the maintenance of a numerous of difficult products allows to offer you the equipment the adapted to your problem.



SINEX INDUSTRIE - 6 route de claix - 16 400 LA COURONNE
 Tél : 05.45.67.18.45 - Fax : 05.45.67.49.61
 Internet : <http://www.sinex-industrie.com>
 E-mail : infos@sinex-industrie.com

Ref : NCA 02.08
 Date : 26/11/03
 2-2